

Southern Oregon Speedway

ASCS SPRINT

RULES

2009

All rules will apply with the exception in 2009. You may use ASCS legal heads or ASCS legal intake manifold gasket. In 2010 ASCS legal heads only!

Engine Rules

1. 360 Cubic Inches: plus 1% maximum displacement (360 plus 1% = 363.6).
2. No aluminum blocks. No Titanium in engines, excluding valves and valve retainers.
3. Injectors: 2 3/16 inch maximum inside diameter of injector stack - 2.187 at least 3 inches in length. Note: Larger injectors may be used, but sleeves a minimum of 3 inches in length must be installed in stacks above the Butterflies. No relief hole may be drilled above the Butterfly on any injector. No Alteration of injector manifold mounting holes will be allowed.

Due to manufacturing process some injector stacks may be slightly larger. There will be a tolerance of .005 allowed on no more than 3 stacks. No throttle body or plenum type injectors allowed, No down nozzle injectors.

No timed fuel injectors will be allowed. Electronic fuel injection shall not be allowed. Only one injector nozzle and one injector line per cylinder. Injection unit shall have one shaft operated butterfly per cylinder. The immediate area of the butterfly must be round. No slide or barrel type injectors will be allowed.

4. Spec Heads: Brodix heads part # 27-211, #27223, and #27-222 with ASCS stamp may not have any performance-enhancing alterations in any way. Intake opening no larger than original opening, the only exception being, inlet opening may be ground or polished 3/4 inches or no further into port than the closest edge of the closest letter of the ASCS logo. During this polishing the left side of the letter "A" is sometimes inadvertently brushed with polish wheel. This is permissible as long as letter is still intact. During polishing of inlet port sometimes polish marks may go slightly further than the 3/4 inch. Intake port at no time may exceed 215 cubic centimeters.

Intake port polishing will be allowed no more than 1 1/2 inches below the bottom of the original seat ring on the back side of the bowl area and no more than 1 inch on the short side. Polishing will be allowed in the combustion chamber area to avoid hot spot chaffing. Polishing will be allowed in exhaust ports as long as the original "ASCS" logo is not affected or port shape is not altered substantially.

Absolutely no intake or exhaust port relocation, raising, enlargement or reshaping of any type. Valve angle and placement may not be altered in any way on the ASCS spec head or on any other head. ASCS checking fixtures to check the above specifications and dimensions will be used by sanctioned ASCS tracks.

Any internally repaired ASCS spec head must be re-certified by Brodix.

5. All spec heads must remain within 1 degree of the original manufacturing.
6. Penalty for altered spec head will be subject to suspension, for one calendar year. Forfeit all points and moneys won, during the race which the infraction was found, and subject to a \$500 fine that must be paid to *ASCS* before reinstatement. Intake port at no time may exceed 215 cubic centimeters.
7. All oil pans must have inspection plug, pans without plug will be subject to pan removal at anytime.
8. No Turban driven, Turbo or blower will be allowed.
9. Only two valves and one spark plug per cylinder allowed. No big blocks.
10. No computer operated or controlled parts, such as fuel injections, fuel systems, chassis adjusting systems, etc.
11. No offset motors will be allowed, engine must be directly in front of driver. Driver must straddle drive-line.
12. No roadster type chassis allowed, only sprint appearing type bodies, tails and hood will be allowed.
13. Any car changing a motor after taking an official green flag will start at the back of the A Main.

Chassis Specs

1. **Weight Rule:** Weight rule is 1475 lbs., including the driver, at the conclusion of the race. Any bolt-on weight must be painted white and the car number must be on the weight. Loss of any bolt-on weight during competition will disqualify the individual from that event. Bolt-on weight can only be added in the areas designated in the accompanying diagram. The weight must be securely attached and must remain in place during a race. It must not be moved or removed during a red flag situation. We reserve the right to disqualify any individual whose weight mounting procedure does not meet our specifications. (see illustration)

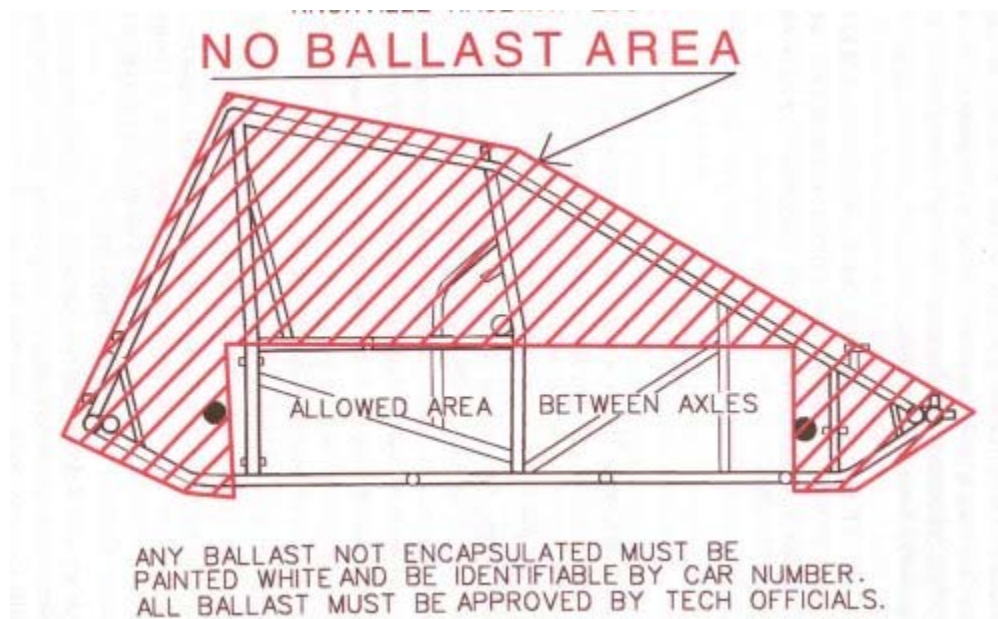

2. **Wings**
Top Wing: (see Illustration)
 - a) Center Foil maximum size of 25 square feet with a maximum width of 60 inches with a one degree plus or

minus tolerance.

b) Center Foil shall be fully sheathed in aluminum. Vent holes are strictly prohibited.

c) No wicker bills or Gurney lips permitted on Center Foil, unless center foil is totally flat then a one-inch wickerbill is allowed.

d) Other than the slider mechanism, no moving parts allowed on or in foil structure.

e) The 12-inch section located at the rear of the Center Foil must not have the belly/curl arc out of proportion with the rest of the Center Foil. The belly/curl arc must span the entire length of the Center Foil and appear to be a gradual arc with the deepest point no further back than 48 inches from the leading edge. As measured on a 12-inch straight edge, the belly at 6 inches from the rear of the Foil may not be deeper than $\frac{1}{2}$ inch. There is zero tolerance on this $\frac{1}{2}$ inch depth. It is suggested that the wing blue print specify $\frac{15}{32}$ -inch depth, so that if any deflection or movement of the wing occurs, the depth will not exceed the $\frac{1}{2}$ inch specification. (This $\frac{1}{2}$ inch measurement ensures that the belly/curl arc is gradual.)

f) Beginning in 2010 wings will be flat and square with a 1 inch wickerbill.

g) The belly/curl arc must start at the radius of the Center Foil's leading edge and shall not exceed a depth of $2\frac{1}{2}$ inches. Center Foil thickness cannot exceed 9 inches. Center Foil top surface from side to side must remain flat. Center Foil must be one-piece construction. No split or bi-wings will be permitted. Wings must be fabricated of metal alloys only. No fiberglass, carbon fiber or other similar material may be used in the basic framework of the wings. Top wing must not extend beyond outside of rear tires.

h) Two stationary foils or rudders will be allowed to run the entire length of the underneath portion of the top wing. Maximum height proportions are 1 inch at the front and 3 inches at the rear. Nowhere shall the foil exceed 3 inches in height. The top wing can be cockpit/driver adjustable

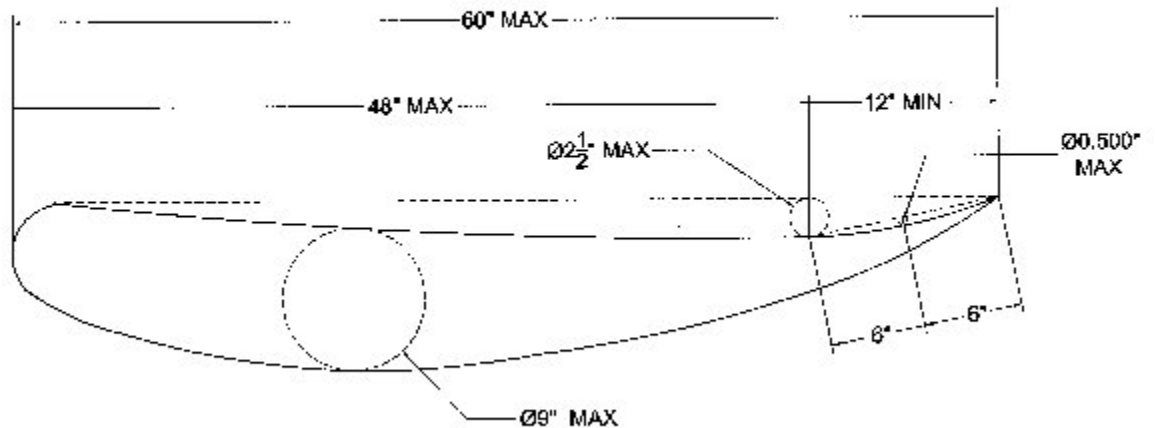

*Front Wing: (see Illustration)

a) Center Foil maximum size of 6 square feet with a maximum width of 36 inches with a one degree plus or minus tolerance.

b) Center Foil shall be fully sheathed in aluminum. No vent holes allowed.

- c) No wicker bills or Gurney lips permitted on Center Foil, unless center foil is totally flat then a one-inch wickerbill is allowed.
- d) Maximum distance from the Center Foil front edge to the front edge of the front axle may not exceed 20 inches.
- e) The Center Foil front edge must remain at least 1 inch behind the front edge of the front bumper. Center Foil top surface from side to side must remain flat.
- f) Center Foil must be one piece. No split or bi-wings will be allowed.
- g) Wings must be fabricated of metal alloys only. No fiberglass, carbon fiber or other similar material may be used in the basic framework of the wings.
- h) The Front Wing must not extend beyond outside of front tires. The Front Wing may not be cockpit or driver adjustable while the car is stationary or in motion.
- i) No moving parts allowed on or in foil structure.
- j) The 5" section located at the rear of the front foil must not have a bell/curl arc that is out of proportion with the rest of the front foil. As measured on a 5-inch straight edge, the belly at 2 ½ inches from the rear of the foil may not be deeper than 3/8 inch. There is zero tolerance on this 3/8-inch depth. It is suggested that the wing blue print specify 11/32-inch depth, so that if any deflection or movement of the wing occurs, the depth will not exceed the 3/8-inch specification (This 3/8 inch measurement ensures that the belly/curl arc is gradual).
- k) The belly/curl arc must span the entire length of the front foil and appear to be a gradual arc with the deepest point, no further back than 12 inches from the leading edge. The belly/curl arc must start at the front foil's leading edge and shall not exceed a depth of 2 inches. Top foil thickness cannot exceed 3.6 inches.
- l) No rudders or fins on Front Wings.

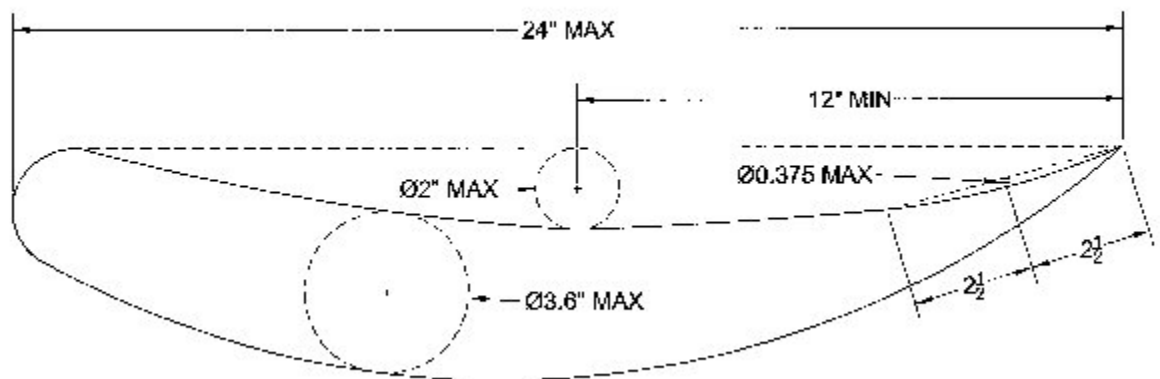

*Side Board Panels

- a) All side board panels must be within an eight-degree plus or minus tolerance.
- b) Side panels may not be supported by braces whose section is not horizontal. All braces or supports shall be oriented thin edge to face the air stream. Only rectangular, round or oval metal braces not exceeding 1 inch in width may be used.

c) No aero section side panel brace material allowed.

d) No brace or support shall resemble a wicker bill or a split wing.

Top Wing sideboards maximum size, 72 inches long and 30 inches tall. Panels must be of one-piece construction. Panels must be fabricated flat so as to have no turnouts or flaps made of more than 2 inches of material on the front or rear of panel and no more than 1 1/4 inches on the top or bottom.

Front Wing side boards maximum size, 12 inches tall and 26 inches long with no more than one inch overhang from the center foil front edge to the side board front edge. Sideboards may have front, back, top and bottom turnouts of no more than 1/2 inch.

3. Any sprint chassis is allowed, but it must pass any test prescribed by the safety inspectors. The roll cage must be of a four-post design. No dirt champ cars. No elliptical (oval shaped) tubing used on or as part of the main frame structure. Minimum wheel-base of 83 inches, maximum wheel-base of 90 inches.
4. Fuel cell securely mounted with bladder mandatory. Tank used for qualifying heats must remain for all events.
5. No flammable liquids allowed in cooling systems. No fuel additives.
6. Bumpers and nerf bars are mandatory and must be securely mounted. No aluminum frames, rear bumpers or nerf bars. Aluminum front bumpers are allowed. Nerf bars must not be outside of tires.
7. All drive lines must be broken in the coupler or rear slider, fully enclosed and contain no more than one U-joint or C-V joint. No torque arm drive lines allowed. A safety strap is strongly recommended.
8. Mufflers: Mandatory, (unless otherwise stated). Schoenfeld part #112535. Loss of muffler will result in disqualification when mufflers are required.
9. Headers: Must be a minimum of .045.
10. Steel, aluminum or titanium brake rotors only.
11. Raceceiver Radios are mandatory; we reserve the right to penalize drivers that don't run a Raceceiver. No two way radios will be allowed.
12. The maximum distance from the leading edge of the front bumper to the leading edge of the front torsion tube is a maximum of 8". The maximum distance from the leading edge of the front bumper to the leading edge of the front axle is 23 1/2 inches.
13. No hollow, tubular or drilled out bolts allowed.
14. The right side opening must be a minimum of 10 inches vertical at any point and 21 inches horizontal.

Tires and Wheels

1. Right Rear Hoosier Racing Tire, stamped Medium or Hard 105 X 16. No tire preps or tire softeners allowed.
2. Beadlocks recommended on all wheels.

3. Maximum right wheel width is 18-inches, maximum left rear wheel width is 15 inches.
4. Left Front is the only tire you can run flat.

Fuel

1. Methanol or Ethanol only, NO NITRO or additives allowed. Fuel subject to be checked anytime by *ASCS* officials. NOTE: Fuel samples may be taken for analysis and prize money may be withheld until results are known. (Penalty for fuel infraction will result in forfeiture of all points and moneys won during event detected, and a fine up to \$1000 for first infraction. 2nd infraction subject to suspension up to 1 calendar year.)

Safety

1. All drivers are required to wear SNELL approved helmet, a fire retarding uniform, protective gloves and arm restraints during competition.
2. All cars must be equipped with adequate seat belts, shoulder harness and crotch strap. *ASCS* strongly recommends a five point hookup with 3 inch belts.

Protest

1. Protest will be taken only from a driver or car owner and then only if the protest is in writing and accompanied by the appropriate protest fee in cash to *ASCS* officials. In the event the protested car is found to be legal, the protest fee shall be given to the owner of the car protested minus a fee that shall be paid to the inspector.
2. All protest must be filed within ten (10) minutes after the completion of the last race of the evening. All protest shall be decided upon by *ASCS* or his representative. Any appeal of official decision must be filed in writing within ten (10) minutes of notification with *ASCS* and forwarded to the *ASCS* Board of Directors whose decision shall be final.
3. No protests will be accepted on judgment decisions.
4. In the event a car is protested and found to be illegal by the inspector, the driver and car protested shall have all points and money forfeited that were won during the particular race program in question and may be suspended.

Protest Fees (Figures In Parenthesis Are Filing Fees)

1. Motor tear down (heads off) and cylinders inspected: \$800 (\$100).
2. P & G fuel test \$800 (\$100).
3. Other technical protest: \$200 (\$100).

SPORTSMANSHIP – Sprint car racing is a very emotional sport. As such, good sportsmanship is the key element of any competitive racing program. This must include respect for all participants – drivers, owners, pit crews, and officials. For our part we will make every effort to be consistent with our rules regardless of whom or what is involved. We will treat all participants with respect and expect similar treatment in return. A racer's pit area is his castle – therefore please stay out of other racer's pit areas, especially after an incident where you have been involved with that racer. Drivers – remember that you are responsible for the actions of your crews. Any offending parties will be fined appropriately and disciplinary actions will be initiated as deemed necessary.